



**MAN CLA 49.280 6x4**  
Tractor Head



# MAN CLA 49.280 6x4 Tractor Head

## MAN Advantage

- ▶ BS-III Compliant, MAN D-0836 Turbo charged, Inter cooled Engine with microprocessor based Engine Management System, Environment friendly, Fuel Efficient, Most reliable.
  - ▶ MAN **Planetary Axle** with **Hub Reduction** and **Inter Axle Lock** providing superior traction, higher ground clearance. Unmatched reliability.
  - ▶ MAN patented **Exhaust Valve Brakes (EVB)** in combination with LSV and ABS provides extra safe braking and long life.
  - ▶ High gradeability for smooth driving on steep gradients and also in off road conditions.
  - ▶ New generation aerodynamic high roof sleeper cabin with twin beds with heat and sound dampeners. Hydraulically operated tilt cabin mechanism - Maximum comfort and safety for driver.
- Prompt and efficient after sales service provided by a nation wide network of main and associate dealers, parts depots, mobile service vans, 24x7 helpline.

## Applications

- ▶ For all trailer applications (flat bed for cargo, skeletal for containers, low bed for equipment, tipping for aggregates / coal etc., tankers for water, fuel, chemicals, gas, cement bulkers, refrigerated trailer etc.)

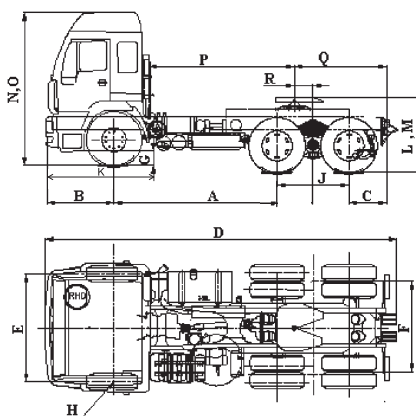

## Technical Specifications

### Dimensions (mm.)

Wheelbase (A+J/2)	3875
Front Overhang (B)	1320
Rear Overhang (C)	725
Overall Length (D)	6829
Front Track (E)	2075
Rear Track (F)	1816
Minimum Ground Clearance (At Front) (G)	270
Turning Radius (H)	9250
Distance between two rear axle (J)	1400
Cabin Length (K)	2046
King Pin Height from Ground (Unladen) (L)	1395
King Pin Height from Ground (Laden) (M)	1345
Overall Height from Ground (Unladen) (N)	3062
Overall Height from Ground (Laden) (O)	3022
King Pin Offset from Cabin Back (P)	2782 / 2572
King Pin Offset from Chassis End (Q)	1792 / 2002
King Pin Offset from Centre of Rear Axles (R)	367 / 577

### Weights in kg

	Unladen (Kerb Weight)*	Laden
Front Axle	3430	6000
Rear Axle	4350	19000
Total	7780	25000
Gross Combination Weight (with 3 Axle Trailer)		49000

\* Nominal Values

### Engine

Engine	MAN D-0836 LFL 08
Type	DI, Turbo Charged Intercooled
No. Of Cylinders	6, Inline
Displacement	6.9 Litres
Max Power output	280 HP (206 kW) @ 2400 r/min
Max Torque	1100 Nm @ 1300-1700 r/min
Emission Compliance	BS-III (Euro-III)
Fuel Tank	335 Litres
Engine Management System	Microprocessor based ECU

**Clutch** : Single Plate – Pull Type, Power Assisted, 430 mm Dia

**Gearbox** : ZF 9S 1110 OD, 9-speed Synchronmesh Gearbox with Crawler Gear

**Front Axle** : Heavy Duty Cranked Forged I-Beam type, maintenance free Hub Bearings

**Rear Axle** : MAN H9 & HD9 13120 Planetary Tandem Bogie with Hub Reduction & Interaxle Lock & Stabiliser Bar

Rear Axle Ratio : 7.63 : 1

**Chassis Frame** : C-channel rolled section, side-members and cross-members made of high-strength steel

**Steering** : Power steering - ZF 8043, Telescopic & Adjustable

**Brakes** : S-Cam, Dual-circuit, Air Actuated Drum brakes, Drum Dia 410 mm., Automatic slack adjuster and asbestos-free brake linings, ABS, Exhaust Valve Brake (EVB).

### Suspension :

Front : Semi Elliptical Leaf springs with Double Acting Shock absorbers

Rear : Heavy Duty Bogie type suspension, Stabiliser bar.

**Cabin** : MAN L-CAB (High Roof Sleeper) with 2 Sleeper Bunks, Hydraulic Cab Tilt with tilt angle of 60 degrees.

### Wheels & Tyres :

Wheel Rim Size 7.5" x 20"

Tyres 11.00" X 20" Cross Ply (11R20 Optional)

Twin Mounted Tyres on Drive Axles, Spare wheel with tyre.

### Electrical System:

Double pole wiring system with separate ground wire Harness enclosed in safe sheathing/casing

Battery capacity 2x100 Ah, 24V

Alternator capacity 80 AMP

Trailer Connections : 2" Compatible 5th wheel coupling. Two Pneumatic coiled hoses for trailer brake connection. 7 pole electrical connection for trailer.

### Performance Data :

Max. Gradeability Crawler Gear	28 %
Max. Startability Crawler Gear	23 %
Max. Speed (in Top Gear)	78 kmph
Economy Speed Range on Top Gear	45-58 kmph

## MAN Trucks India Pvt. Ltd.

Mumbai Pune Road, Akurdi, Pune - 411 035. INDIA

Tel. : +91 20 27476381 Fax : +91 20 27475984

www.mantrucksindia.com

A member of the MAN Group

Printed in INDIA

Text and illustrations not binding.

Subject to changes in the course of technical progress.

