



MAN CLA 25.220 6x2
Chassis with Cab



MAN CLA 25.220 6x2 Chassis and Cab

MAN Advantage

- ▶ BS-III Compliant, MAN D-0836 Turbo charged, Inter cooled Engine with microprocessor based Engine Management System, Environment friendly, Fuel Efficient. Most reliable.
- ▶ Extra Strong ladder frame chassis, special high strength steel provides high torsional and bending stress capability. Specially treated for corrosion resistance.
- ▶ MAN patented **Exhaust Valve Brakes (EVB)** in combination with LSV provides extra safe braking and long life.
- ▶ High gradeability for smooth driving on steep gradients and also in off road conditions.
- ▶ New generation aerodynamic high roof sleeper cabin with twin beds with heat and sound dampeners. Hydraulically operated tilt cabin mechanism - Maximum comfort and safety for driver. Prompt and efficient after sales service provided by a nation wide network of main and associate dealers, parts depots, mobile service vans, 24x7 helpline.

Applications

- ▶ Cargo Truck (with Hydraulic Crane or Tail Gate lift), Panel Van, Refrigerated Body etc.
- ▶ Tanker for drinking water, milk, fuel, chemicals, sewage etc.
- ▶ Special Purpose Vehicles (Fire Tender, Refuse Collector, Hydraulic Platform etc.)

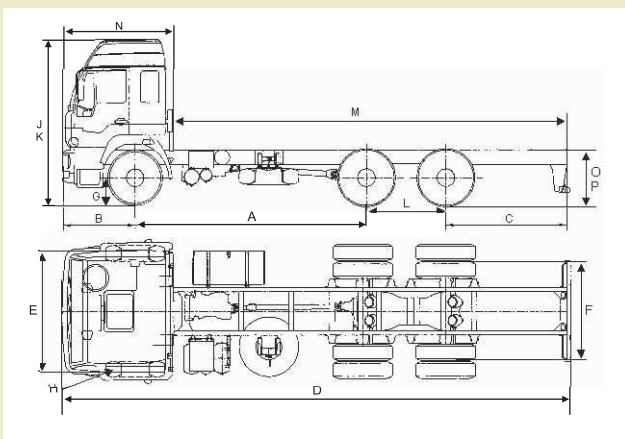

Technical Specifications

Dimensions (mm.)

Wheelbase (A+L/2)	4915
Front Overhang (B)	1320
Rear Overhang (C)	2170
Overall Length (D)	9183
Front Track (E)	2075
Rear Track (F)	1816
Minimum Ground Clearance (At Front) (G)	270
Turning Radius (H)	8500
Overall Height from Ground (Laden) (J)	3017
Overall Height from Ground (Unladen) (K)	3057
Distance between Two Rear Axle (L)	1430
Available Platform Length (M)	7120
Cabin Length (N)	2046
Chassis Height from Ground (Unladen) (P)	1157
Chassis Height from Ground (Laden) (O)	1112

Weights in kg

	Unladen (Kerb Weight)*	Laden
Front Axle	3250	6000
Rear Axle	3600	19000
Total	6850	25000

* Nominal Values

Engine

Engine	MAN D-0836 LFL 16
Type	DI, Turbo Charged Intercooled
No. Of Cylinders	6, Inline
Displacement	6.9 Litres
Max Power output	220 HP (162 kW) @ 2400 r/min
Max Torque	800 Nm @ 1200-1800 r/min
Emission Compliance	BS-III (Euro-III)
Fuel Tank	335 Litres
Engine Management System	Microprocessor based ECU

Clutch : Single Plate – Pull Type, Power Assisted, 395 mm Dia

Gearbox : ZF 6S 850 OD, 6-speed Synchronmesh Gearbox

Front Axle : Heavy Duty Cranked Forged I-Beam type, maintenance free Hub Bearings

Rear Axle : Hypoid Axles

Rear Axle Ratio : 6.17 : 1

Chassis Frame : C-channel rolled section, side-members and cross-members made of high-strength steel

Steering : Power steering - ZF 8043, Telescopic & Adjustable

Brakes : S-Cam, Dual-circuit, Air Actuated Drum brakes, Drum Dia 410 mm., Automatic slack adjuster and asbestos-free brake linings, Exhaust Valve Brake (EVB).

Suspension :

Front : Semi Elliptical Leaf springs with Double Acting Shock absorbers

Rear : Heavy Duty, Semi Elliptical Leaf Springs with Bell Crank Mechanism

Cabin : MAN L-CAB (High Roof Sleeper) with two sleeper bunks

Hydraulic Cab Tilt with tilt angle of 60 degrees

Wheels & Tyres :

Wheel Rim Size 7.5" x 20"

Tyres 10.00" X 20" Cross Ply (10R20 Optional)

Twin Mounted Tyres on Drive Axles, Spare wheel with tyre.

Electrical System:

Double pole wiring system with separate ground wire Harness enclosed in safe sheathing/casing

Battery capacity 2x100 Ah, 24V

Alternator capacity 80 AMP

Performance Data :

Max. Gradeability 1st Gear 24 %

Max. Startability 1st Gear 19 %

Max. Speed (in Top Gear) 84 kmph

MAN Trucks India Pvt. Ltd.

Mumbai Pune Road, Akurdi, Pune - 411 035. INDIA

Tel. : +91 20 27476381 Fax : +91 20 27475984

www.mantrucksindia.com

A member of the MAN Group

Printed in INDIA

Text and illustrations not binding.

Subject to changes in the course of technical progress.

